

CS 31 Homework 2: Circuits – due Feb 15 at start of class

Your Name(s)/Lab Section(s):

- Fill in the truth table for the following circuit. Note that this circuit is using NOT, XOR, NOR, NAND, and AND gates.

x	y	z	OP ₁ (x, y, z)	OP ₂ (x, y, z)
0	0	0		
0	0	1		
0	1	0		
0	1	1		
1	0	0		
1	0	1		
1	1	0		
1	1	1		

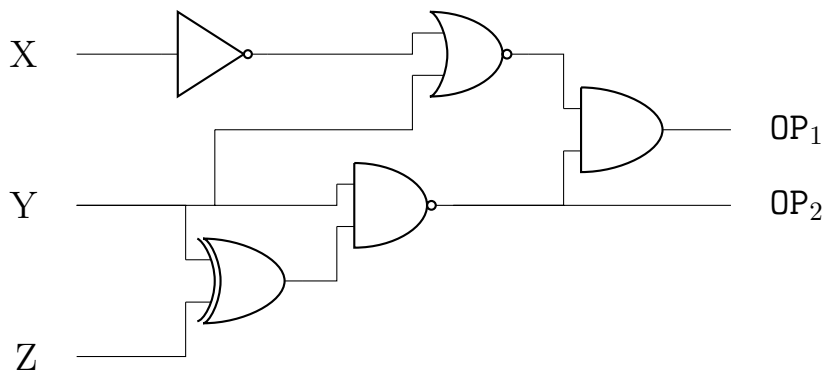

2. Construct a circuit that implements the following truth table. You may use any of the following one- or two-input gates: NOT, AND, OR, XOR, NAND, NOR, XNOR. Write out the boolean expression for OP1 and OP2 before attempting to draw the circuit. HINT: try to come up with a shorter boolean expression by considering the output values for when x is 1, and then for when x is 0.

x	y	z	OP ₁ (x, y, z)	OP ₂ (x, y, z)
0	0	0	0	0
0	0	1	1	1
0	1	0	1	1
0	1	1	1	0
1	0	0	0	0
1	0	1	0	1
1	1	0	0	1
1	1	1	0	1