

CS 31: Intro to Systems Storage and Memory

Kevin Webb

Swarthmore College

October 27, 2022

Reading Quiz

Transition

- First half of course: hardware focus
 - How the hardware is constructed
 - How the hardware works
 - How to interact with hardware / ISA
- Up next: performance and software systems
 - Memory performance
 - Operating systems
 - Standard libraries (strings, threads, etc.)

Efficiency

- How to Efficiently Run Programs
- Good algorithm is critical...
- Many systems concerns to account for too!
 - The memory hierarchy and its effect on program performance
 - OS abstractions for running programs efficiently
 - Support for parallel programming

Efficiency

- How to Efficiently Run Programs
- Good algorithm is critical...
- Many systems concerns to account for too!
 - The memory hierarchy and its effect on program performance
 - OS abstractions for running programs efficiently
 - Support for parallel programming

Suppose you're designing a new computer architecture. Which type of memory would you use? Why?

- A. low-capacity (~1 MB), fast, expensive
- B. medium-capacity (a few GB), medium-speed, moderate cost
- C. high-capacity (100's of GB), slow, cheap
- D. something else (it must exist)

Classifying Memory

- Broadly, two types of memory:
 1. Primary storage: CPU instructions can access any location at any time (assuming OS permission)
 2. Secondary storage: CPU can't access this directly

Random Access Memory (RAM)

- Any location can be accessed directly by CPU
 - Volatile Storage: lose power → lose contents
- Static RAM (SRAM)
 - Latch-Based Memory (e.g. RS latch), 1 bit per latch
 - Faster and more expensive than DRAM
 - “On chip”: Registers, Caches
- Dynamic RAM (DRAM)
 - Capacitor-Based Memory, 1 bit per capacitor
 - “Main memory”: Not part of CPU

Memory Technologies

- Static RAM (SRAM)
 - 0.5ns – 2.5ns, \$2000 – \$5000 per GB
- Dynamic RAM (DRAM)
 - 50ns – 100ns, \$20 – \$75 per GB
 - (Main memory, “RAM”)

We’ve talked a lot about registers (SRAM) and we’ll cover caches (SRAM) soon. Let’s look at main memory (DRAM) now.

Dynamic Random Access Memory (DRAM)

Capacitor based:

- cheaper and slower than SRAM
- capacitors are leaky (lose charge over time)
- Dynamic: value needs to be refreshed (every 10-100ms)

Example: DIMM (Dual In-line Memory Module):

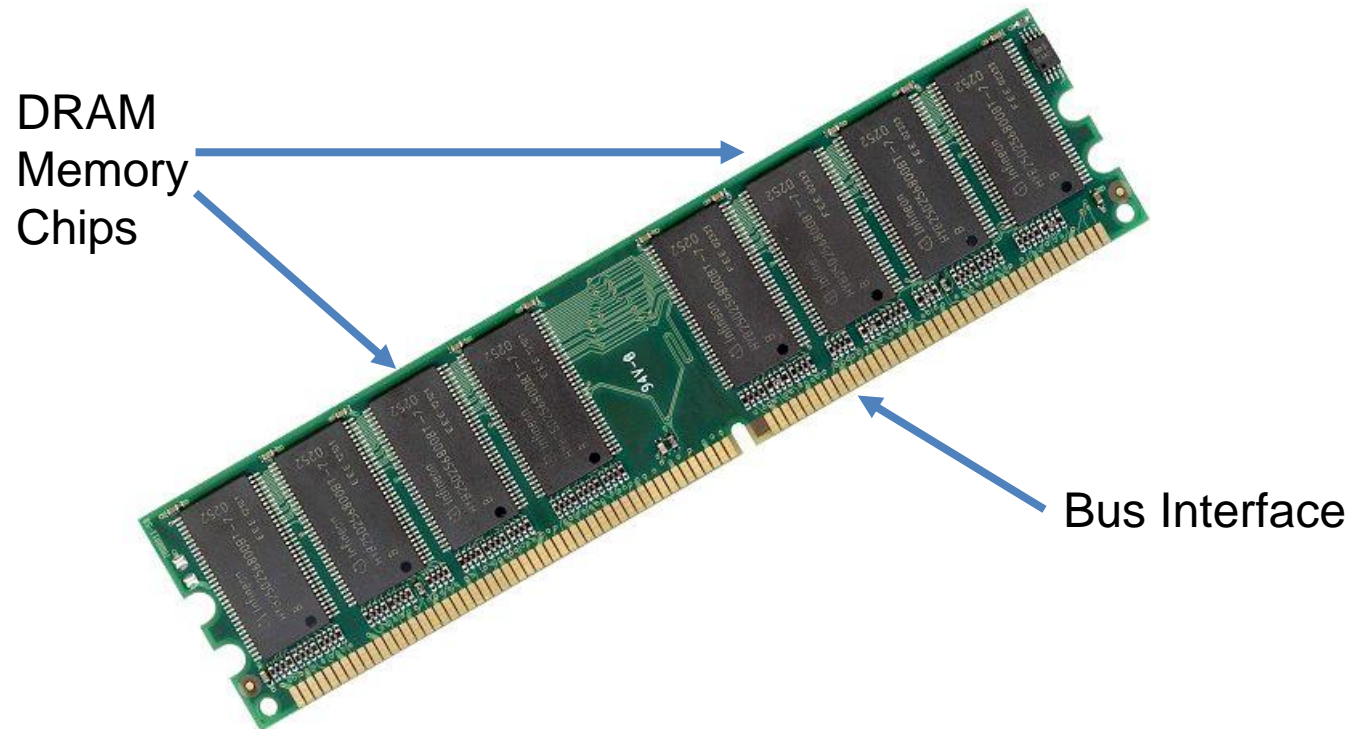

Connecting CPU and Memory

- Components are connected by a **bus**:
 - A bus is a collection of parallel wires that carry address, data, and control signals.
 - Buses are typically shared by multiple devices.

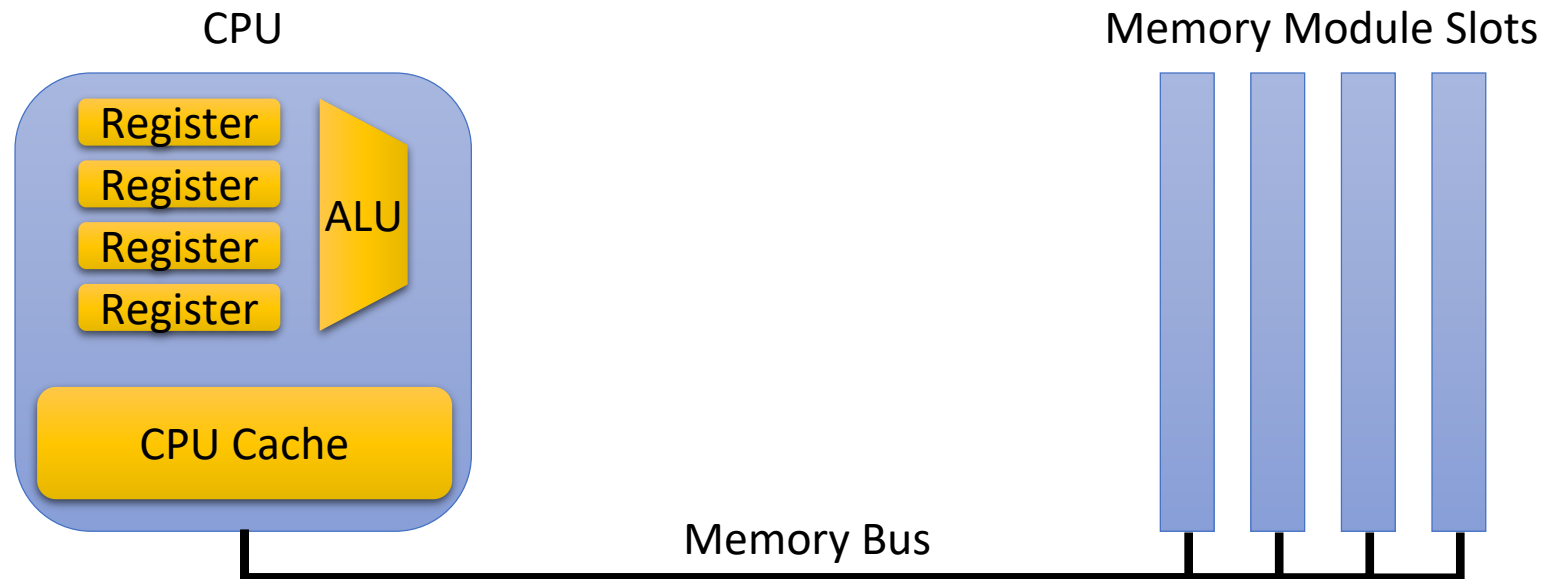

How Memory Read Works

(1) CPU places address A on the memory bus.

Load operation: `ldr x0, [Address A]`

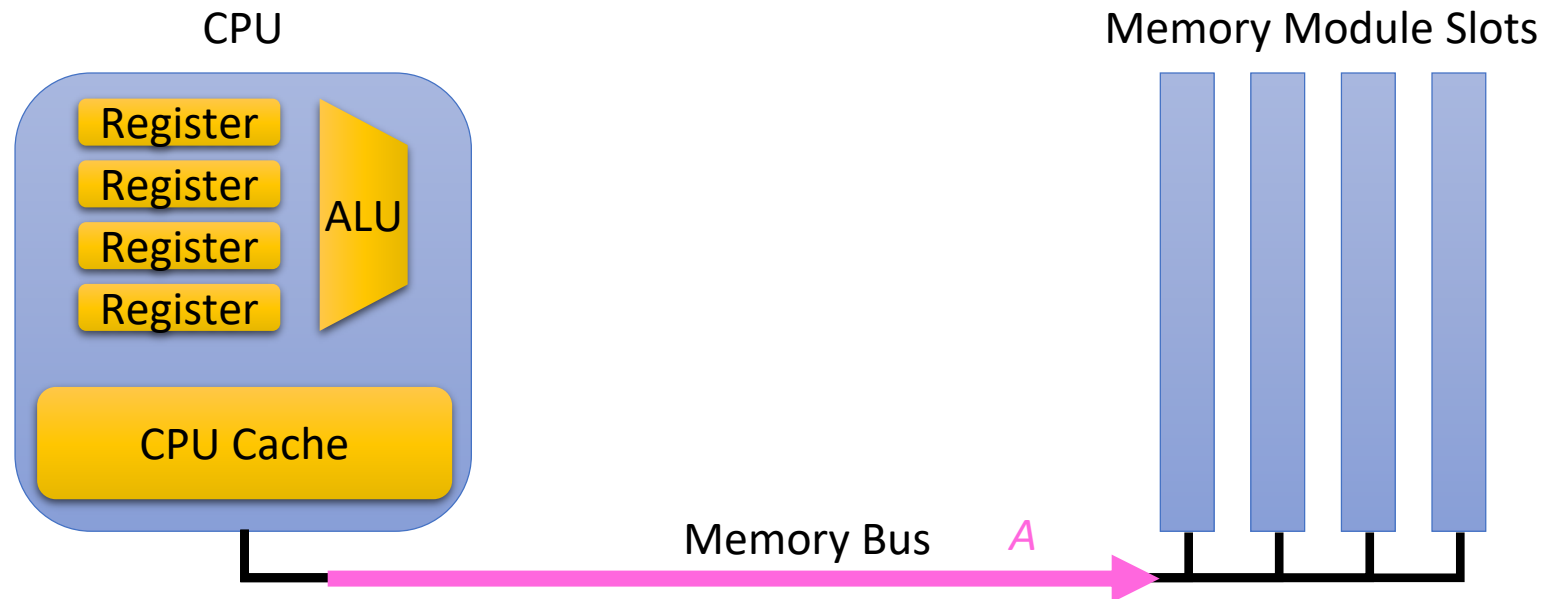

Read (cont.)

- (2) Main Memory reads address A from memory, fetches value at that address and puts it on the bus

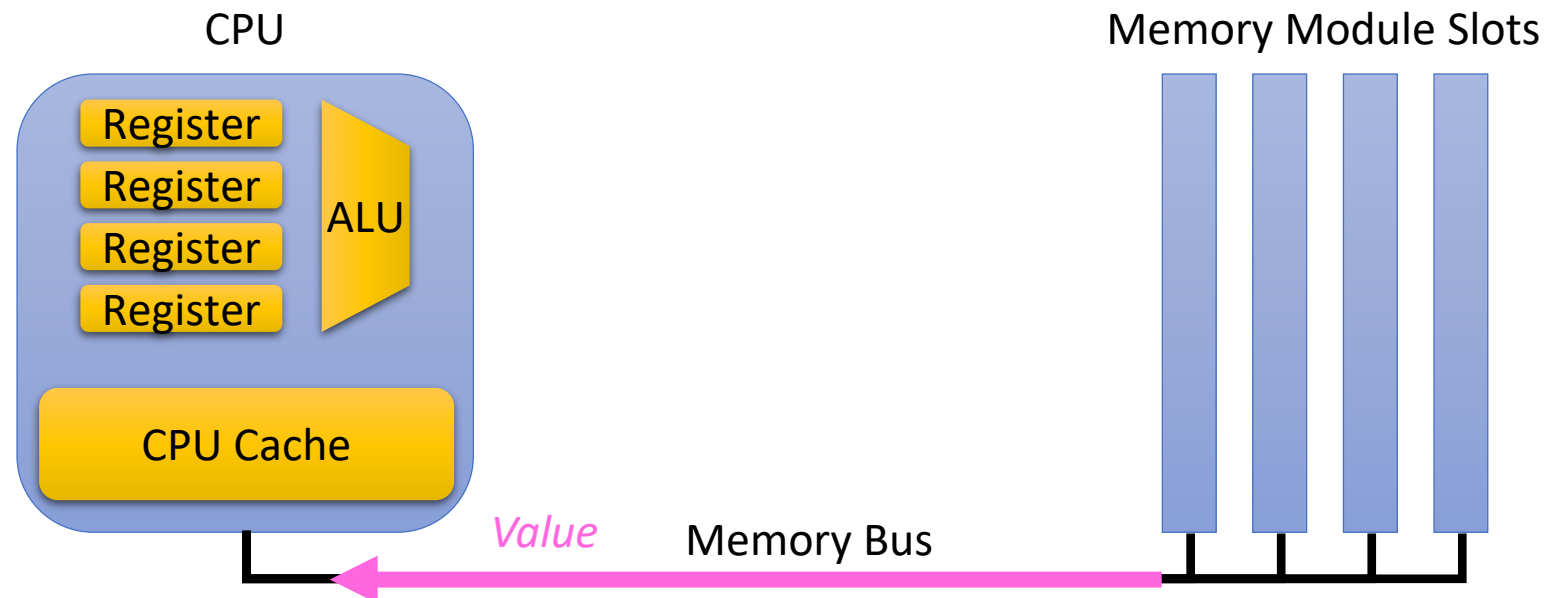

Read (cont.)

- (3) CPU reads value from the bus, and copies it into register x0, a copy also goes into the on-chip cache memory

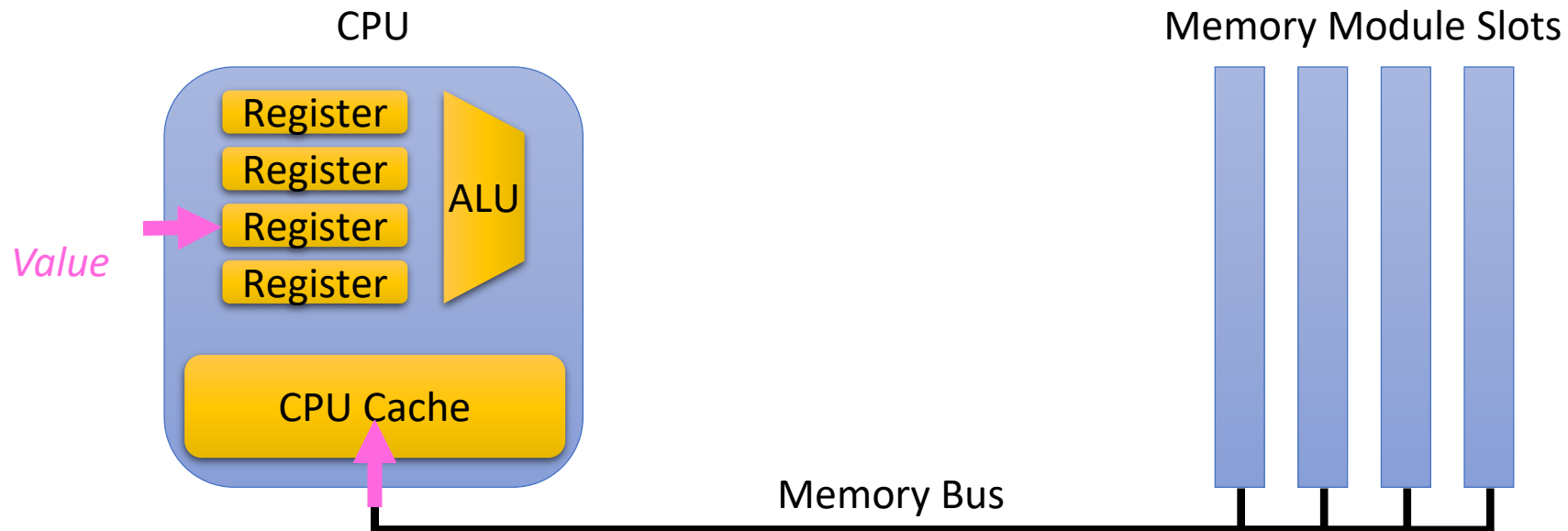

Write

1. CPU writes A to bus, memory reads it
2. CPU writes value to bus, memory reads it
3. Memory stores value at address A

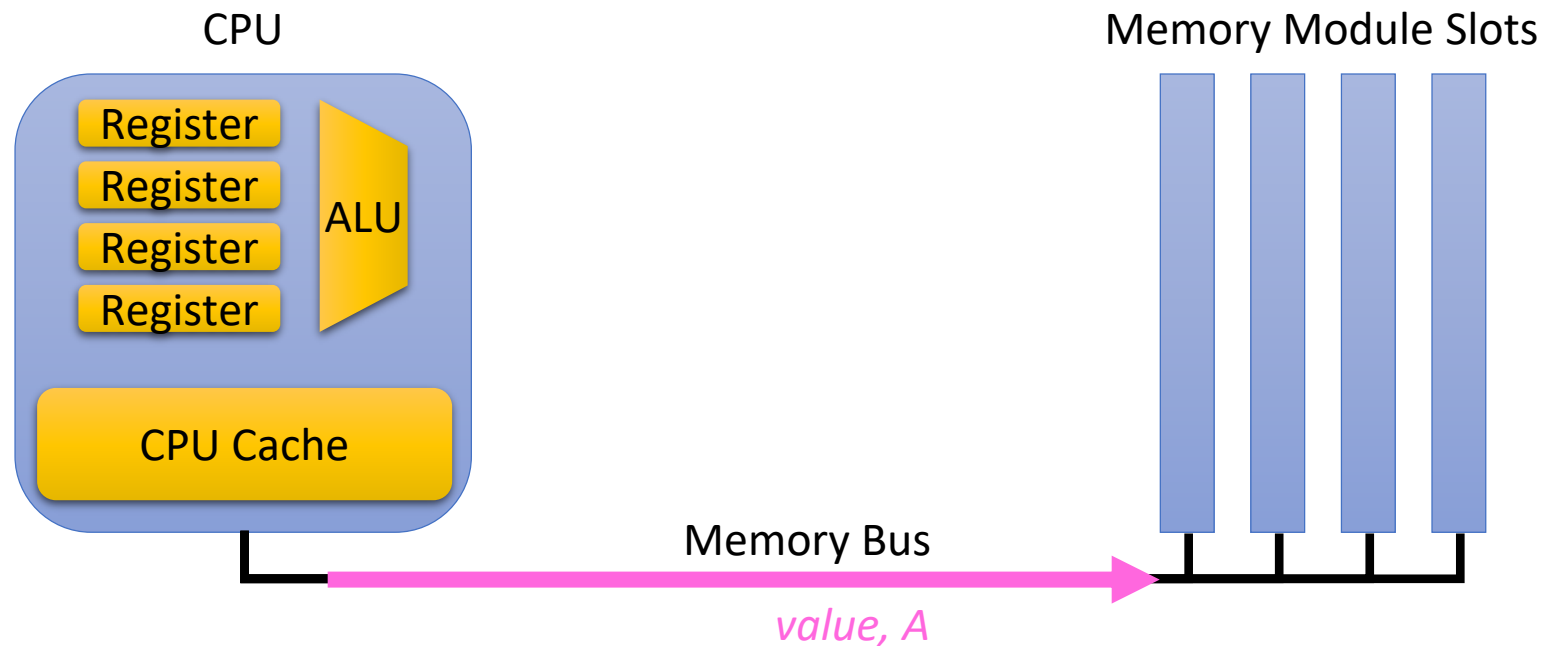

Secondary Storage

- Disk, Tape Drives, Flash Solid State Drives, ...
- Non-volatile: retains data without a charge
- Instructions CANNOT directly access data on secondary storage
 - No way to specify a disk location in an instruction
 - Operating System moves data to/from memory

Secondary Storage

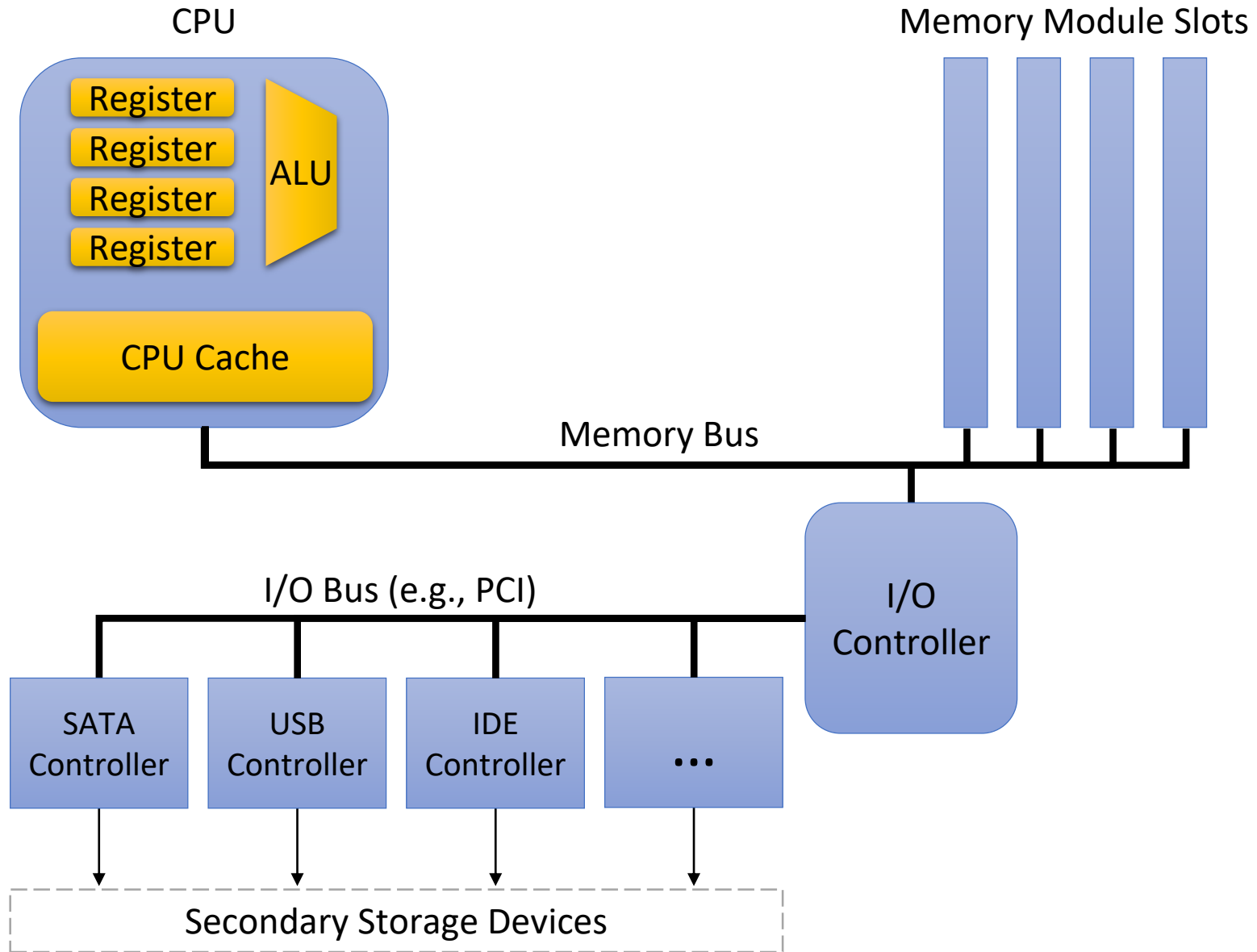

What's Inside A Disk Drive?

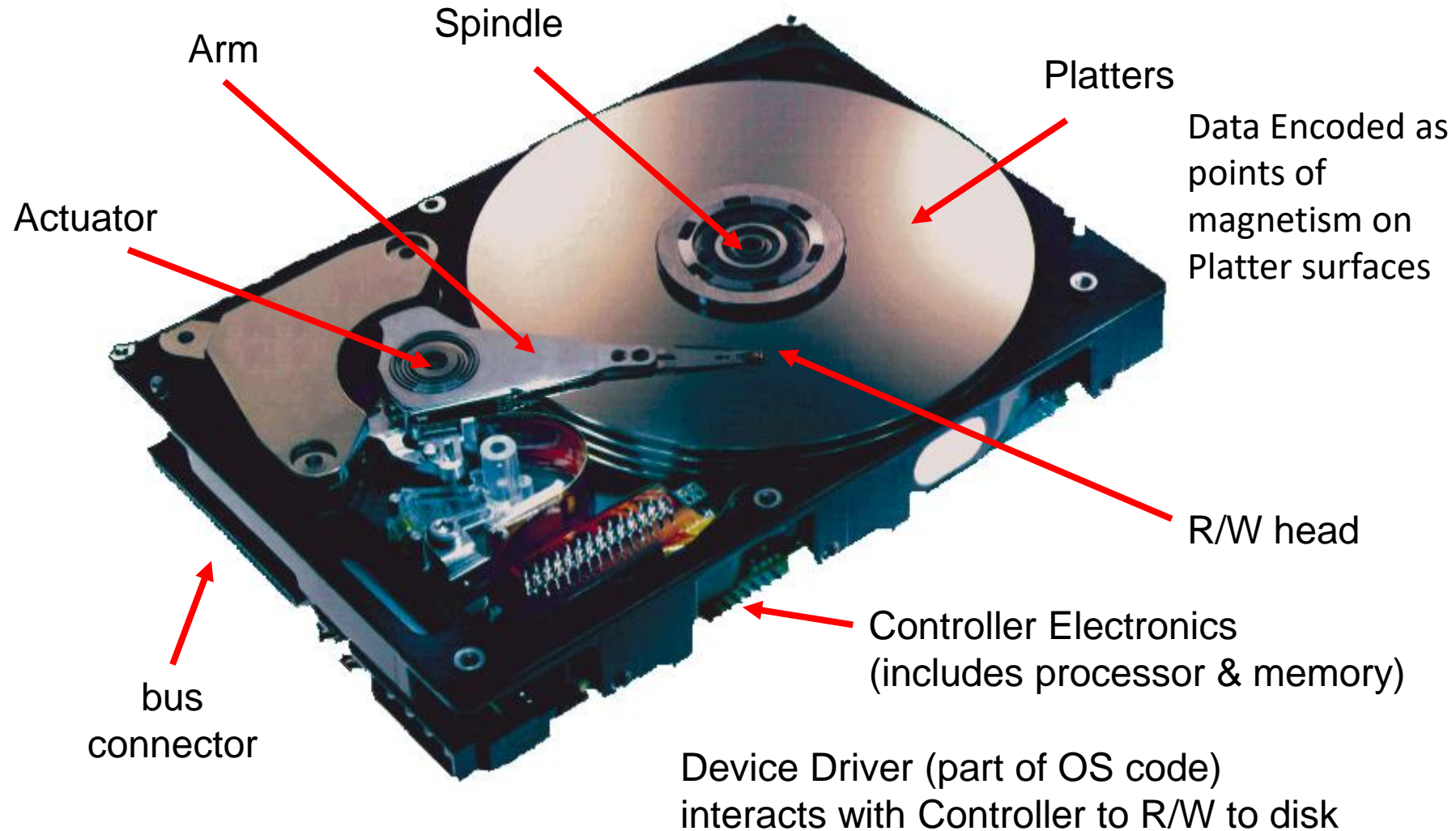
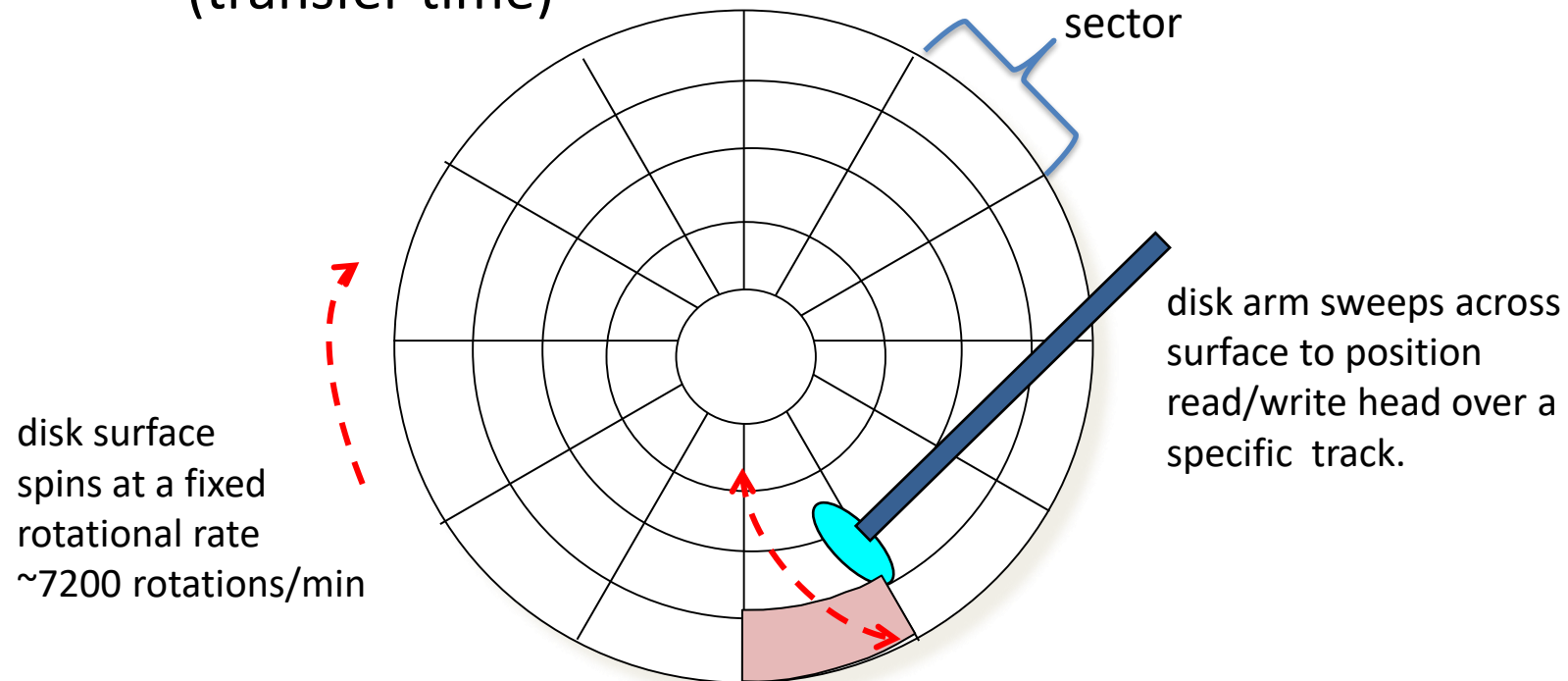

Image from Seagate Technology

Reading and Writing to Disk

Data blocks located in some **Sector** of some **Track** on some **Surface**

1. Disk Arm moves to correct **track** (seek time)
2. Wait for **sector** spins under R/W head (rotational latency)
3. As sector spins under head, data are Read or Written (transfer time)



Memory Technology

- Static RAM (SRAM)
 - 0.5ns – 2.5ns, \$2000 – \$5000 per GB

Like walking:

Down the hall

- Dynamic RAM (DRAM)
 - 50ns – 100ns, \$20 – \$75 per GB

Across campus

Solid-state disks (flash): 100 us – 1 ms, \$2 - \$10 per GB

- Magnetic disk
 - 5ms – 15ms, \$0.20 – \$2 per GB

To Seattle

 1 ms == 1,000,000 ns

The Memory Hierarchy

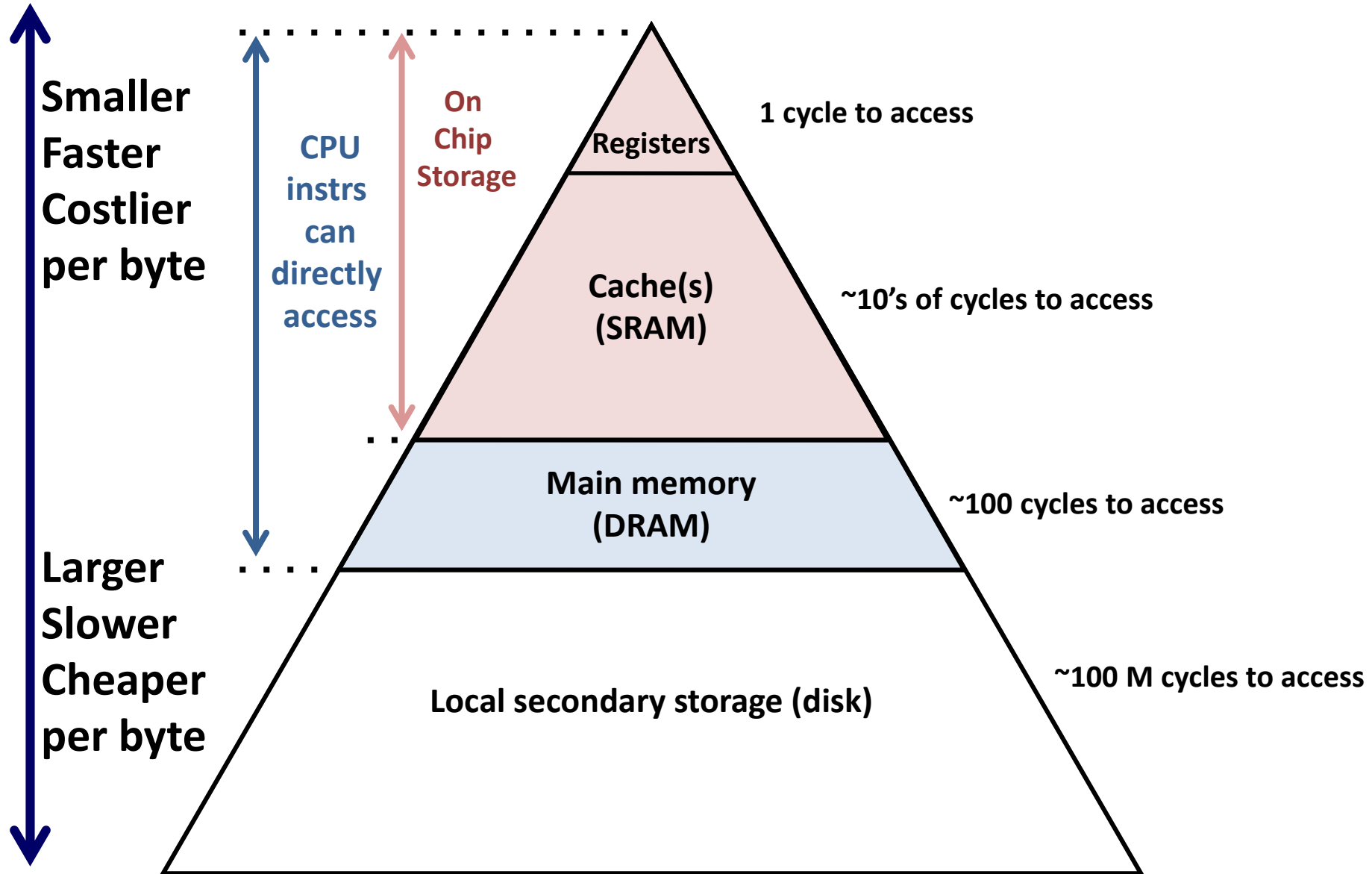

Where does accessing the network belong?

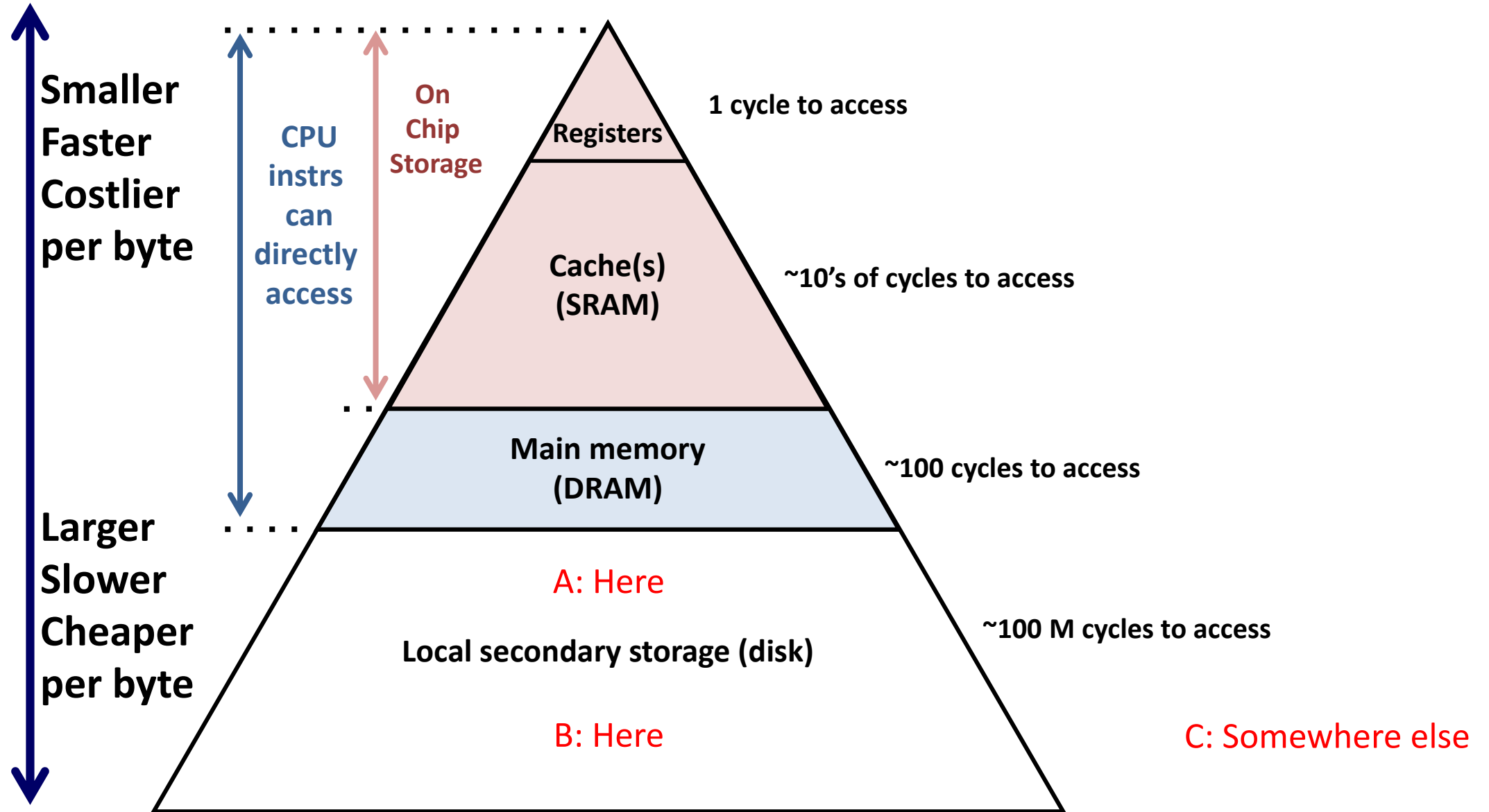

The Memory Hierarchy

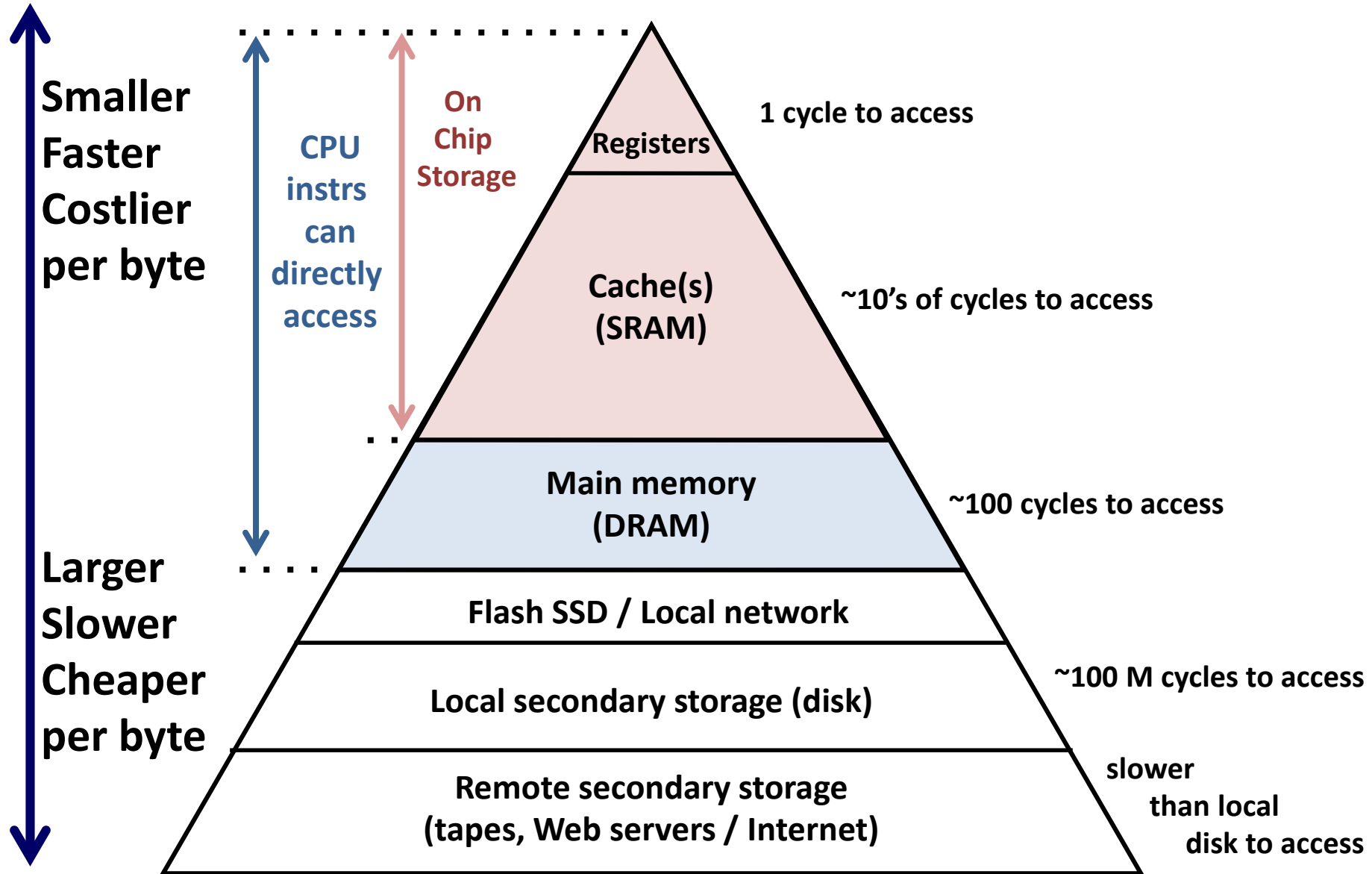

Abstraction Goal

- Reality: There is no one type of memory to rule them all!
- Abstraction: hide the complex/undesirable details of reality.
- Illusion: We have the speed of SRAM, with the capacity of disk, at reasonable cost.

Motivating Story / Analogy

- You work at a video rental store (remember Blockbuster?)
- You have a huge warehouse of movies
 - 10-15 minutes to find movie, bring to customer
 - Customers don't like waiting...
- You have a small office in the front with shelves, you choose what goes on shelves
 - < 30 seconds to find movie on front shelf

The Video Store Hierarchy

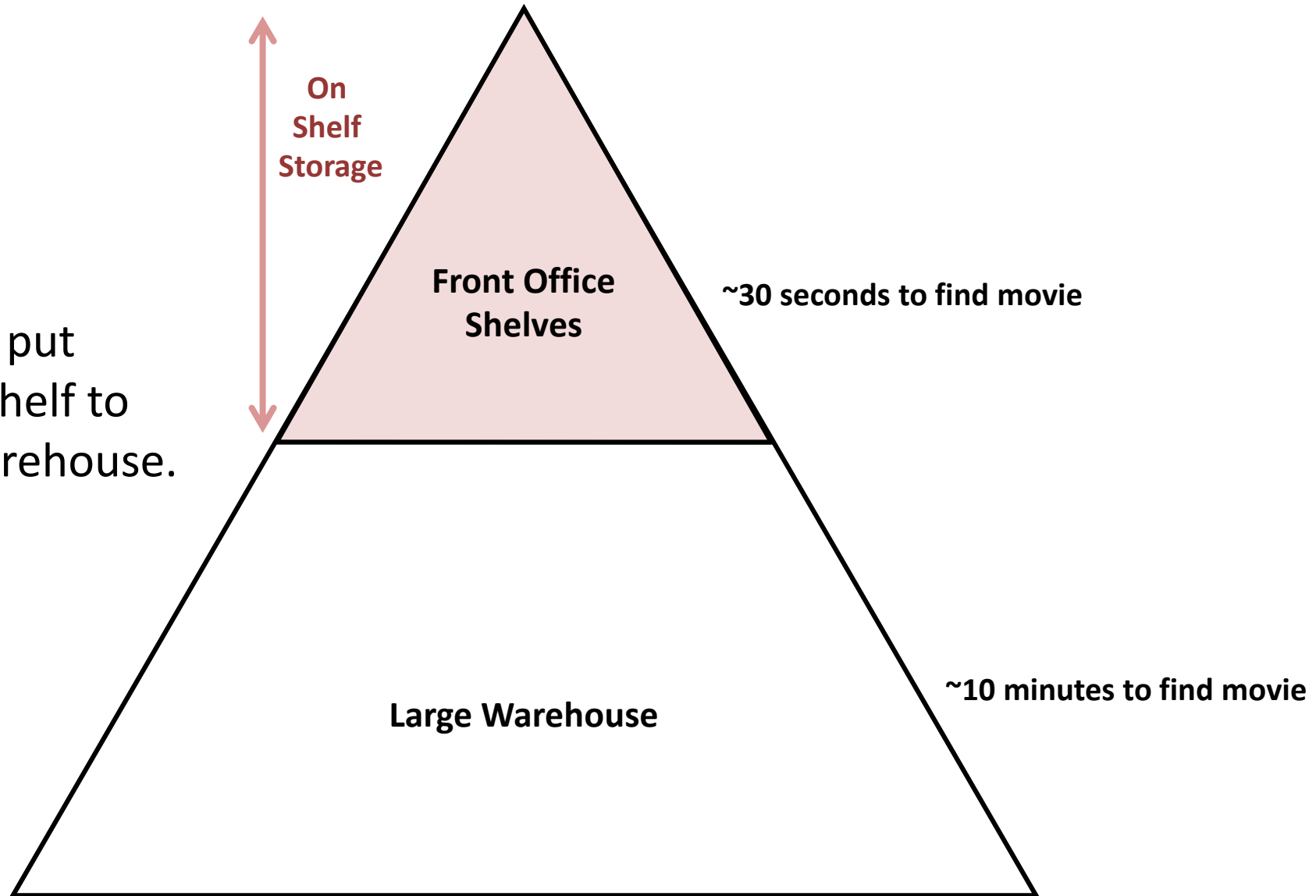

Goal: strategically put movies on office shelf to reduce trips to warehouse.

Quick vote: Which movie should we place on the shelf for tonight?

- A. Eternal Sunshine of the Spotless Mind
- B. The Godfather
- C. Pulp Fiction
- D. Rocky V
- E. There's no way for us to know.

Problem: Prediction

- We can't know the future...
- So... are we out of luck?
What might we look at to help us decide?
- The past is often a pretty good predictor...

Repeat Customer: Bob

- Has rented “Eternal Sunshine of the Spotless Mind” ten times in the last two weeks.
- You talk to him:
 - He just broke up with his girlfriend
 - Swears it will be the last time he rents the movie (he’s said this the last six times)

Quick vote: Which movie should we place on the shelf for tonight?

- A. Eternal Sunshine of the Spotless Mind
- B. The Godfather
- C. Pulp Fiction
- D. Rocky V
- E. There's no way for us to know.

Repeat Customer: Alice

- Alice rented Rocky a month ago
- You talk to her:
 - She's really likes Sylvester Stalone
- Over the next few weeks she rented:
 - Rocky II, Rocky III, Rocky IV

Quick vote: Which movie should we place on the shelf for tonight?

- A. Eternal Sunshine of the Spotless Mind
- B. The Godfather
- C. Pulp Fiction
- D. Rocky V
- E. There's no way for us to know.

Critical Concept: Locality

- Locality: we tend to repeatedly access recently accessed items, or those that are nearby.
- Temporal locality: An item that has been accessed recently is likely to be accessed again soon. (Bob)
- Spatial locality: We're likely to access an item that's nearby others we just accessed. (Alice)

In the following code, how many examples are there of temporal / spatial locality?

Where are they?

```
int i;
int num = read_int_from_user();
int *array = create_random_array(num);
for (i = 0; i < num; i++) {
    printf("At index %d, value: %d", i, array[i]);
}
```

- A. 1 temporal, 1 spatial
- B. 1 temporal, 2 spatial
- C. 2 temporal, 1 spatial
- D. 2 temporal, 2 spatial
- E. Some other number

Big Picture

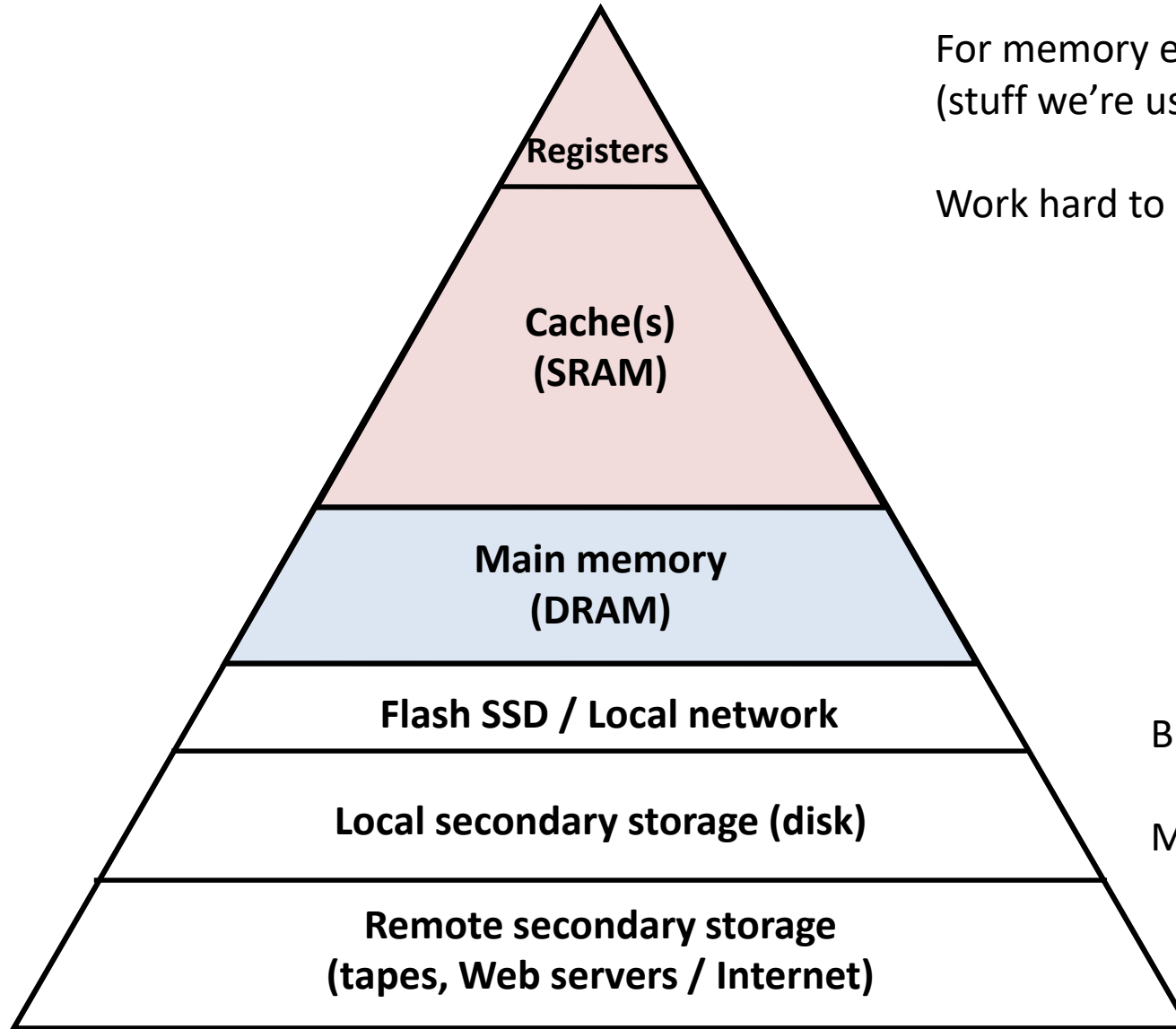

For memory exhibiting locality
(stuff we're using / likely to use):

Work hard to keep them up here!

Bulk storage down here.

Move this up on demand.

Big Picture

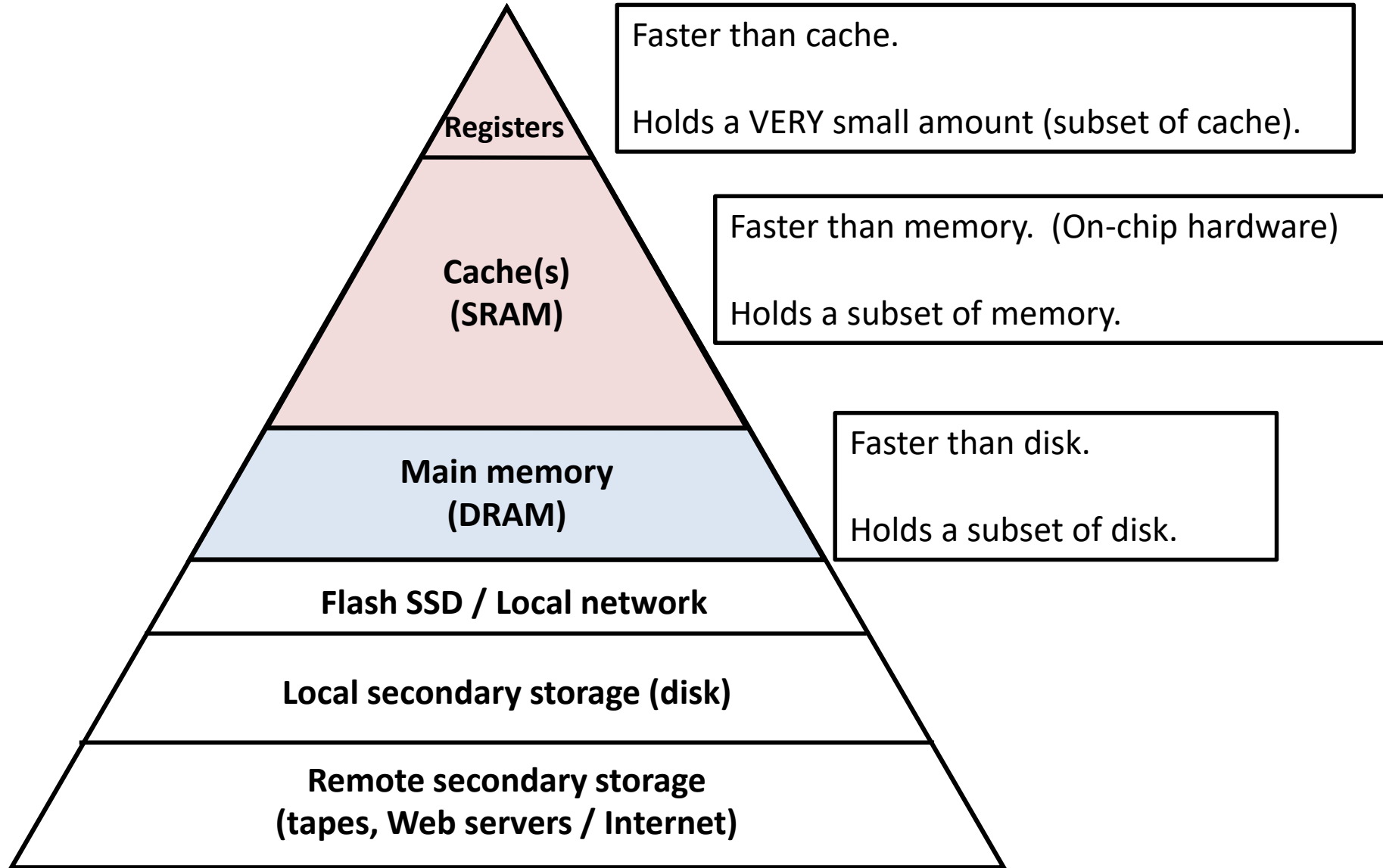

Cache

- In general: a storage location that holds a subset of a larger memory, faster to access
- CPU cache: an SRAM on-chip storage location that holds a subset of DRAM main memory (10-50x faster to access)
- Goal: choose the right subset, based on past locality, to achieve our abstraction

When I say “cache”,
assume this for now.

Cache Basics

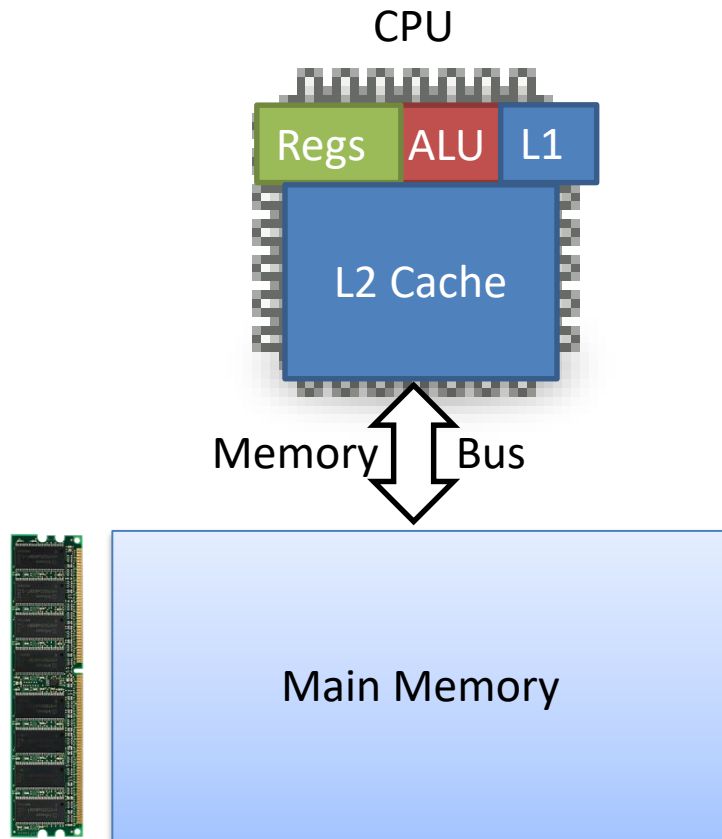

- CPU real estate dedicated to cache
- Usually two (or more) levels:
 - L1: smallest, fastest
 - L2: larger, slower
- Same rules apply:
 - L1 subset of L2

Cache Basics

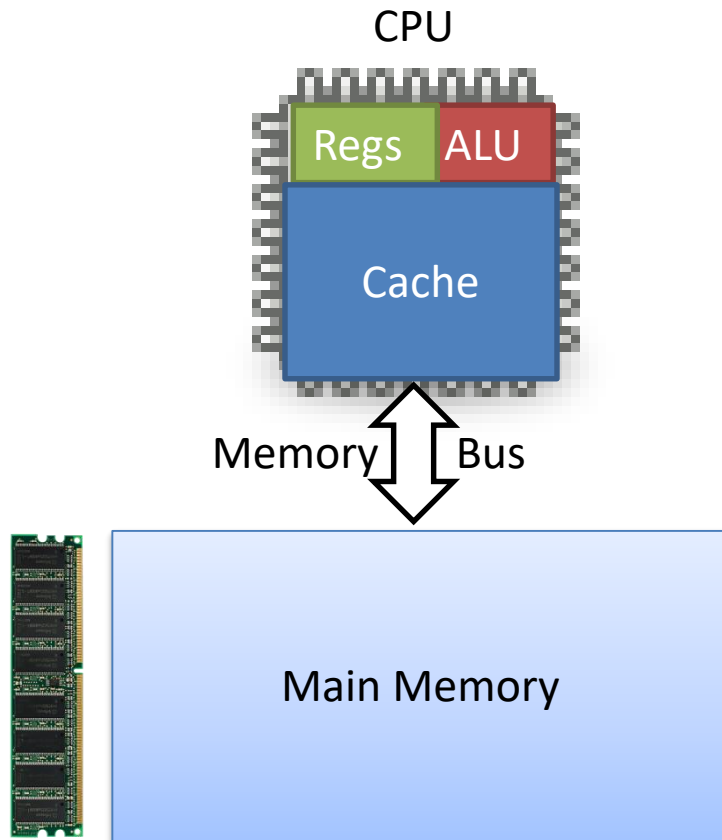

- CPU real estate dedicated to cache
- Usually two levels:
 - L1: smallest, fastest
 - L2: larger, slower
- We'll assume one cache (same principles)

Cache is a subset of main memory.
(Not to scale, memory much bigger!)

Cache Basics: Read from memory

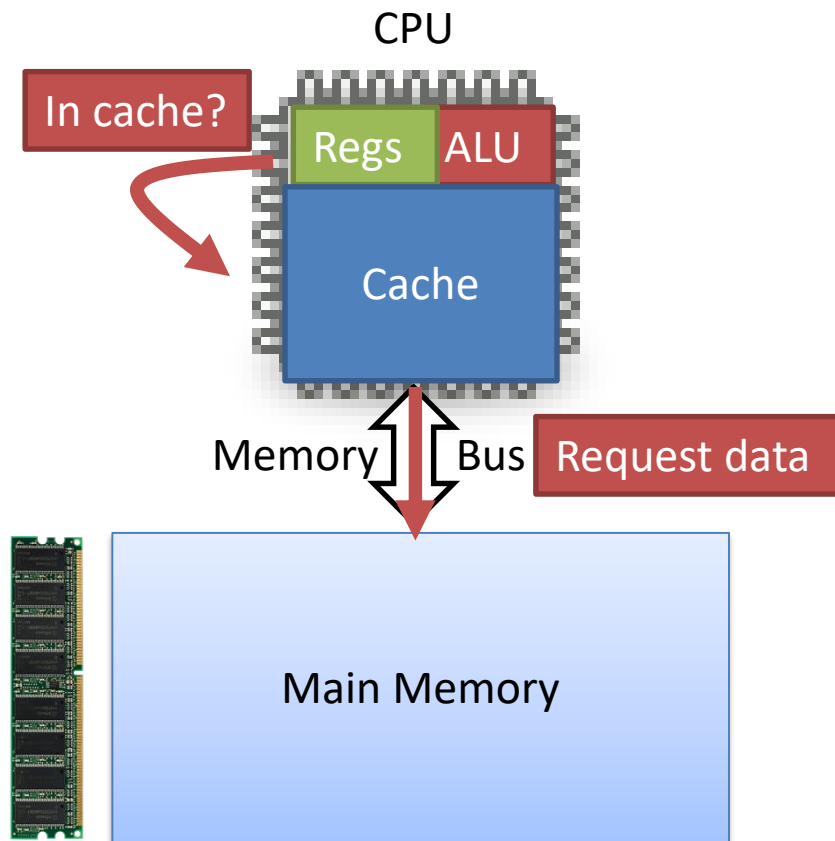

- In parallel:
 - Issue read to memory
 - Check cache

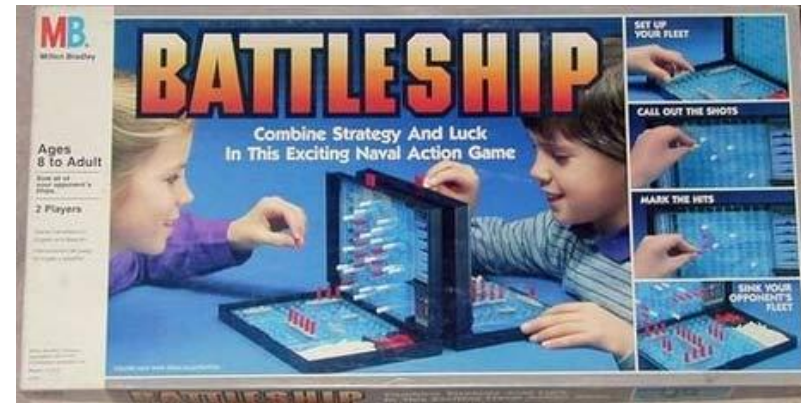

Cache Basics: Read from memory

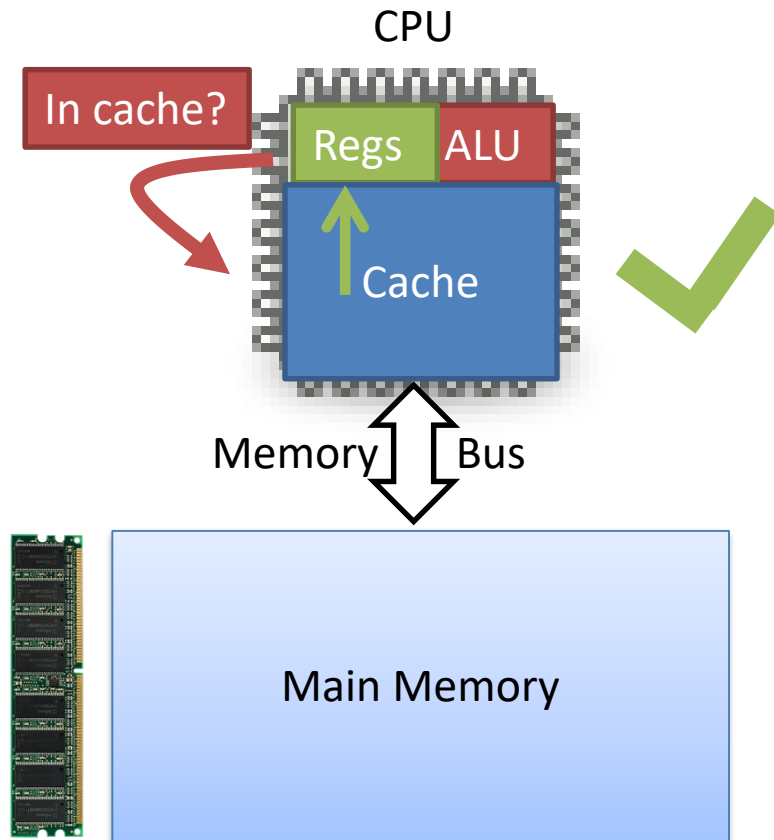

- In parallel:
 - Issue read to memory
 - Check cache
- Data in cache (hit):
 - Good, send to register
 - Cancel/ignore memory

Cache Basics: Read from memory

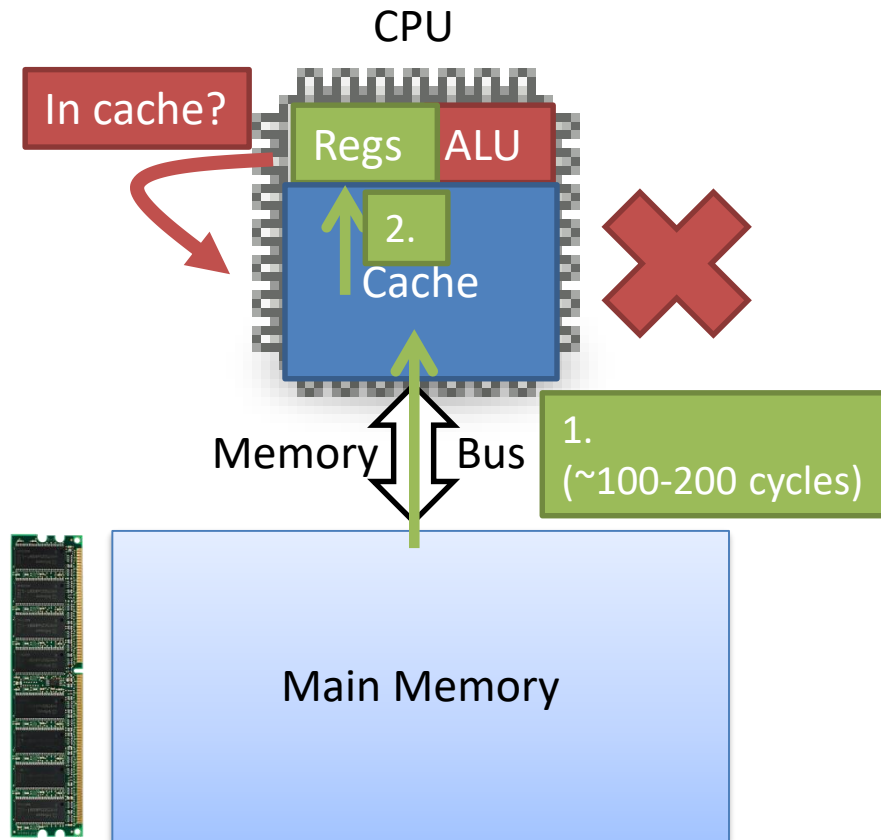

- In parallel:
 - Issue read to memory
 - Check cache
- Data in cache (hit):
 - Good, send to register
 - Cancel/ignore memory
- Data not in cache (miss):
 1. Load cache from memory (might need to evict data)
 2. Send to register

Cache Basics: Write to memory

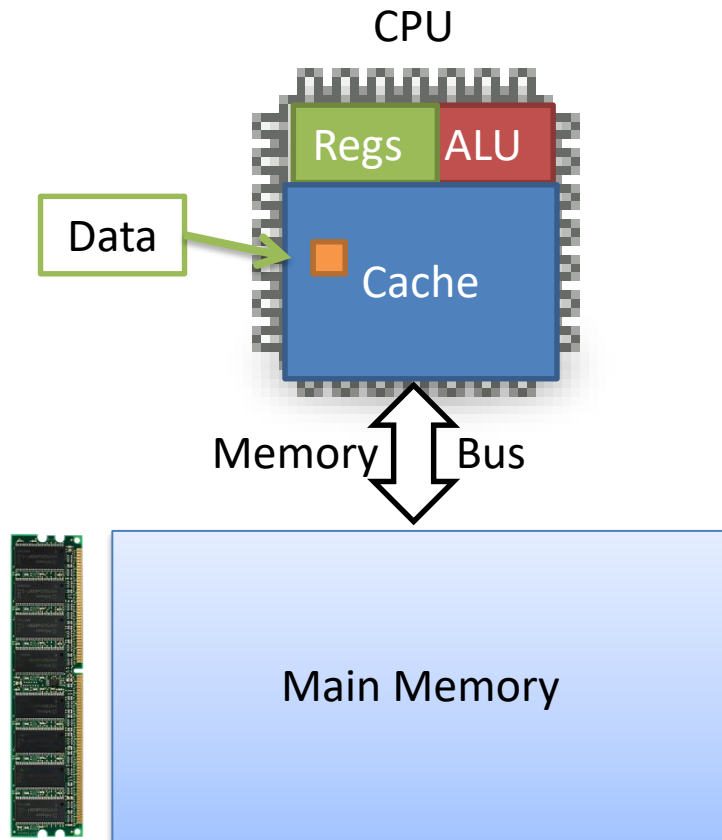

- Assume data already cached
 - Otherwise, bring it in like read
1. Update cached copy.
 2. Update memory?

When should we copy the written data from cache to memory? Why?

- A. Immediately update the data in memory when we update the cache.
- B. Update the data in memory when we remove ("evict") the data from the cache.
- C. Update the data in memory if the data is needed elsewhere (e.g., another core).
- D. Update the data in memory at some other time. (When?)

When should we copy the written data from cache to memory? Why?

- A. Immediately update the data in memory when we update the cache. (“Write-through”)
- B. Update the data in memory when we remove (“evict”) the data from the cache. (“Write-back”)
- C. Update the data in memory if the data is needed elsewhere (e.g., another core).
- D. Update the data in memory at some other time. (When?)

Cache Basics: Write to memory

- Both options (write-through, write-back) viable
- write-through: write to memory immediately
 - simpler, accesses memory more often (slower)
- write-back: only write to memory on eviction
 - complex (cache inconsistent with memory)
 - potentially reduces memory accesses (faster)

Cache Basics: Write to memory

- Both options (write-through, write-back) viable
- write-through: write to memory immediately
 - simpler, accesses memory more often (slower)
- write-back: only write to memory on eviction
 - complex (cache inconsistent with memory)
 - potentially reduces memory accesses (faster)

Sells better.
Servers/Desktops/Laptops



Cache Coherence

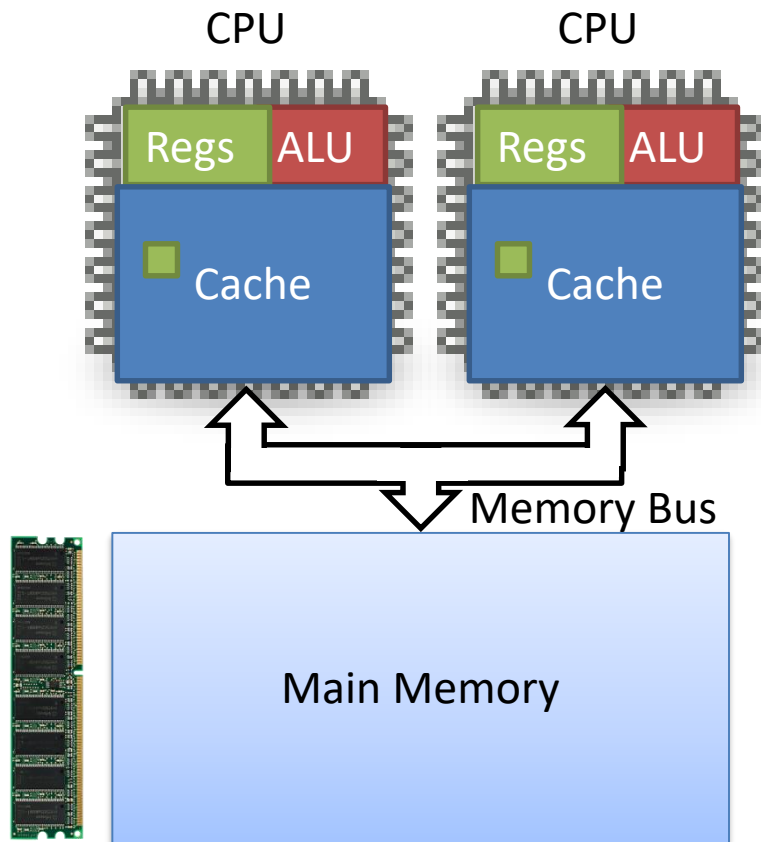

- Keeping multiple cores' memory consistent

Cache Coherence

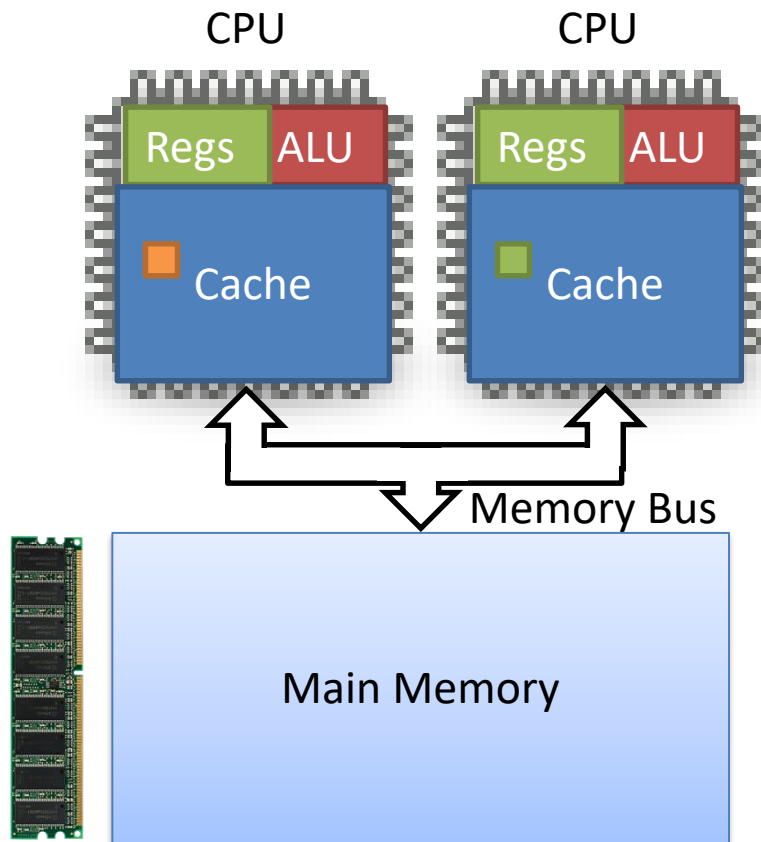

- Keeping multiple cores' memory consistent
- If one core updates data
 - Copy data directly from one cache to the other.
 - Avoid (slower) memory
- Lots of HW complexity here. We might discuss towards end of semester.

Up next:

- Cache details
- How cache is organized
 - finding data
 - storing data
- How cached subset is chosen (eviction)